

**Precise non-contact
temperature measurement
of liquid metals from
1000 °C to 2000 °C
(1832 °F to 3632 °F)**

Features:

- Precise temperature measurement of molten metal
- Decrease of measurement errors at emissivity changes or wrong settings thanks to short wavelength of 525 nm
- Temperature range from 1000 °C to 2000 °C (1832 °F to 3632 °F), measuring fields from 1 mm (0.04 in) and exposure times from 1 ms
- Suited for ambient temperatures of 85 °C (185 °F) without additional cooling, laser switches of automatically at 50 °C (122 °F)
- Optical resolution 150:1, focus settings scalable
- Double laser visor with 2 laser beams for exact measuring field marking and focussing



General specifications

Environmental rating	IP 65 (NEMA-4) front mountable at vacuum processes (up to 10 ⁻³ mbar)
Ambient temperature ¹⁾	-20 °C ... 85 °C (-4 °F ... 185 °F) (sensing head) (50 °C [122 °F] with laser ON) -20 °C ... 85 °C (-4 °F ... 185 °F) (electronics)
Storage temperature	-40 °C ... 125 °C (-4 °F ... 257 °F) (sensing head) -40 °C ... 85 °C (-40 °F ... 185 °F) (electronics)
Relative humidity	10–95 %, non condensing
Vibration	IEC 68-2-6: 3 G, 11–200 Hz, any axis
Shock	IEC 68-2-27: 50 G, 11 ms, any axis
Weight	600 g (21.2 oz) (sensing head) 420 g (14.8 oz) (electronics)

Electrical specifications

Output / analog	0/4–20 mA, 0–5/ 10 V, thermocouple J, K
Output / alarm	24 V / 50 mA (open collector)
Optional	Relay: 2 x 60 V DC / 42 V AC _{eff} ; 0.4 A; optically isolated
Output / digital	USB, RS232, RS485, CAN, Profibus DP, Ethernet (optional)
Output impedances	mA max. 500 Ω (with 8–36 V DC) mV min. 100 kΩ load impedance, thermocouple 20 Ω
Inputs	Programmable functional inputs for external emissivity adjustment, ambient temperature compensation, trigger (reset of hold functions)
Cable length	3 m (standard), 8 m, 15 m (9.8 ft [standard], 26.2 ft, 49.2 ft)
Current draw (laser)	Max. 160 mA
Power supply	8–36 V DC
Laser 635 nm	1 mW, ON/OFF via electronic box or software

Measurement specifications

Temperature range (scalable via programming keys or software)	1000 °C ... 2000 °C (1832 °F ... 3632 °F)
Spectral range	525 nm
Optical resolution (90 % energy)	150:1 (3ML)
System accuracy ²⁾ (at ambient temp. 23 ±5 °C) (at ambient tem. 73 ±9 °F)	±1 % of reading (≤1100 °C) ±(0.3 % of reading +2 °F) (>1100 °C) ±1 % of reading (≤2012 °F) ±(0.3 % of reading +3.6 °F) (>2012 °F)
Repeatability (at ambient temp. 23 ±5 °C) (at ambient tem. 73 ±9 °F)	±0.5 % of reading (≤1100 °C) ±(0.1 % of reading +1 °C) (>1100 °C) ±0.5 % of reading (≤2012 °F) ±(0.1 % of reading +1.9 °F) (>2012 °F)
Temperature resolution (digital)	0.2 K
Exposure time ³⁾ (90 % signal)	1 ms
Emissivity/ Gain (adjustable via sensor or software)	0.100–1.100
IR window correction (adjustable via software)	0.100–1.000
Signal processing (parameter adjustable via software)	Peak hold, valley hold, average; extended hold function with threshold and hysteresis
Software	optris® Compact Connect

¹⁾ The functioning of the LCD display may be limited in ambient temperatures below 0 °C

²⁾ ε = 1, Exposure time 1 s

³⁾ With dynamic adaptation at low signal levels

optris® CTlaser 05M

Optical parameter

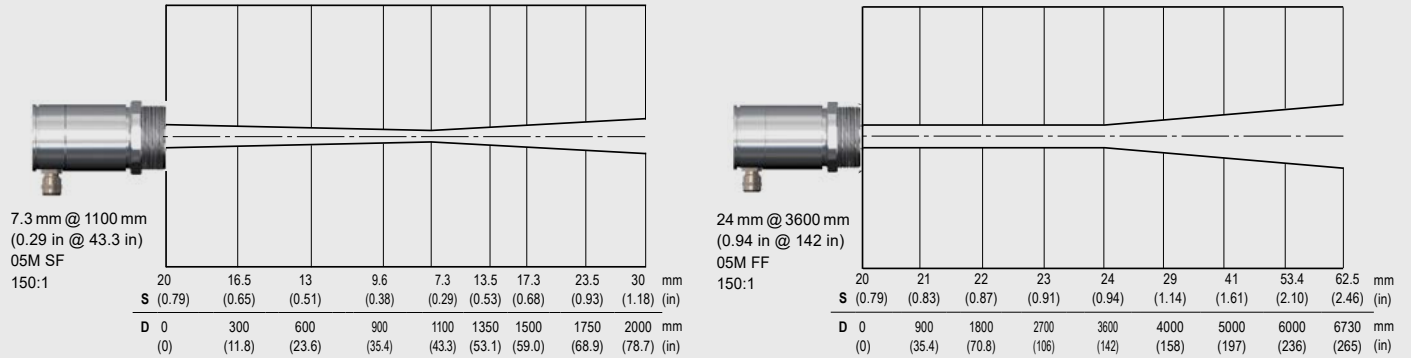

Dimensions

Sensing head



Electronics

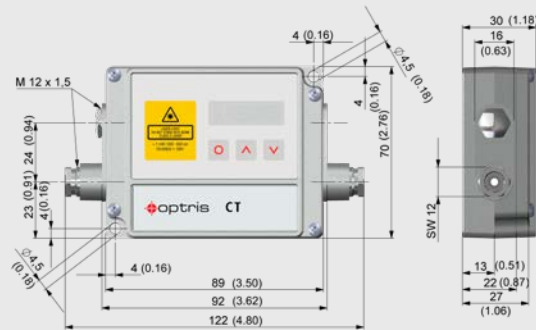

Accessories

Mounting angle, adjustable in two axes (ACCTLAB)



Cooling housing (ACCJCTL)



Mounting angle for cooling housing, adjustable in two axes (ACCJAB)



Water cooling and air purge for sensing head (ACCTLW + ACCTLAP)



Mounting device for cooling housing (ACCLRM)

